



Retrospective on ebXML - 2006

Introduction

For those software engineers who worked on the core initiative that developed ebXML through 1999 and 2000 there seem so many contradictions but also familiar outcomes and events that have spanned the succeeding five years. Any open public initiative has to weather many challenges before it moves into the mainstream of developers consciousness and becomes accepted as part of the fabric of today's leading edge solution mix. More especially for ebXML because of the groundbreaking technology it embodies. For those people who have persevered with ebXML there is now a rich and broad upsurge occurring as implementers worldwide appreciate that there is a very real and effective architecture for implementing internet based electronic business systems (e-Business) using open and public standards and software. Almost all new ebXML work is available as open source and today mainstream vendors such as Oracle, Sun, BEA, SAP, Sybase, Fujitsu and TIBCO also fully support ebXML message exchanges in their commercial solutions as well.

More importantly ebXML has been quietly marching unsung into vital roles in people's everyday lives. Norwegians now have their health insurance needs and health cards managed daily using countrywide ebXML-driven pharmacy transactions for their national insurance program - NIA. Similarly the National Health Service (NHS) in Britain is using ebXML as part of their messaging hub infrastructure nationally. The city of Sydney in Australia has the electricity and gas supply regulated daily using ebXML while Austria is buying and selling electrical power to the European grid. And here in the USA General Motors (GM) is now managing all spare parts distribution to its 8,000 dealerships using ebXML. Likewise Volkswagen (VW) is also making the switch to ebXML worldwide for its supply chain and dealers. In Hong Kong the Metro service support is managed by ebXML and the Chinese Government is investing in ebXML for broad use in industry and government. The US and Canada governments also have ebXML systems in place. There are now literally millions of people worldwide whose lives are being touched in some way by services provided by ebXML-enabled systems.

Globally the ebXML infrastructure is beginning to enter the mainstream of executive business consciousness today. Born from a process began by two organizations – UN/CEFACT¹ and OASIS – who each brought unique backgrounds and solution envisioning together, ebXML has created a new and compelling metaphor for conducting e-Business via the Internet.

¹ See Resources and Glossary at end of document for definition of terms and links to applicable web sites.

Technology

The vision and model for better e-Business using open standards was created by combining the business knowledge gained from twenty years of EDI-based interactions from CEFAC with the OASIS web commerce and marketplace expertise of internet-based companies using XML. That model seeks to move from processes that are highly labour intensive to configure and deploy manually in a paper based culture to a world where trading partners can join today's online commercial revolution and do business electronically by linking their systems together using ebXML and the Internet.

Each step of this process is supported and enabled by ebXML through the use of discreet components that are engineered to deliver specific functionality. Each component can be used individually or combined as needed. Just as GNU/LINUX distributions are widely used by businesses today to run their web sites and services, the ebXML infrastructure provides the means for open and low-cost global commerce.

The business vision is to create new ways for companies to trade globally in secure and reliable digital environments using methods that implement legally valid contracts and exchanges. Also for governments to be able to reach citizens and companies using public standards that provides open access. The ability for small businesses, not just large corporations, to be able to employ the benefits of electronic business processes is also a key requirement.

Security is a key concern and management of exposed connections with partners across the internet. While setting up simple information exchanges is deceptively easy in today's online world, doing so in a way that can be securely and effectively managed is not so trivial. The ebXML approach gives businesses a reliable and scalable on-ramp to the world of electronic business. The mechanisms used support rapid deployment between local partners, but also plug into the bigger grid so that thousands of partners can also be managed without incurring huge support and scaling costs.

Central to this ebXML approach is a set of federated electronic Registry services. This allows partners to discover each other and more importantly to store central definitions and the components that are needed to configure the interchange between them. These can then also be catalogued and shared across an industry community. An example of this is the Universal Business Language (UBL) work that has been developed for supply chain transactions. The Danish government has standardized on UBL for business exchanges in Denmark and accounting software packages are available that support UBL.

Just as with internet file sharing peer-to-peer networks there has to be central nodes that coordinate and facilitate each member's activities and in ebXML the registry performs that role. Aligned with these registry services is the ability to define business partner profiles for formal business process participation. In ebXML parlance these are known as the CPA – *Collaboration Profile Agreement*. These profiles then establish the formal business exchanges between participants. Templates of CPAs can be pre-defined for

common business roles and exchanges within a Community of Practice (CoP) and participants can then simply configure these with their own local parameters using familiar tools such as a web-based form. The resulting CPA forms a single private agreement between two collaborating participants.

The next requirement is to provide secure and reliable communications across the Internet itself. For ebXML a special XML-based messaging transport system based on using the XML SOAP server foundation was developed. This is known as ebMS (*ebXML Messaging Service*) and is universally the most common component used by implementers of ebXML. The ebMS server has now evolved into a sophisticated integration component (see figure 1 below) that not only exchanges messages but also checks trading partner profiles to ensure that the exchanges conform to the business agreements and are being routed accordingly. In the latest version it can also perform business rule checking services and interact with web service based components that conform to the ebXML exchange requirements (see the ebMS V3.0 specifications).

As exchanges develop and become widespread the additional need then is to document and model these process flows. This allows participants to understand their role and context and how the electronic transaction exchanges underscore the actual business process steps themselves. For this the ebXML specifications provide the *Business Process Specification Schema* (BPSS) to allow business analysts to formally define the actions and controls needed in workflow between participants. Modelling tools can then be used to describe and diagram these *business activity models* at a level the business staff can verify; while the BPSS definition of the XML scripting syntax allows software to be instructed to actually implement and run and manage those processes.

Put together these components today are being used to deploy a variety of business solutions. Examples include supply of spare parts and maintenance support for the Metro Rail in Hong Kong; Banking and Insurance services in Korea; in Australia the Electricity and Gas supply in Sydney and small farmers selling wheat to cooperatives; raw steel distribution in Europe's 24x7 steel marketplace; the US DOD EMALL for logistics parts purchase; and the State of Texas electricity distribution marketplace. These examples illustrate the range from small to large configurations.

Next we look at how specifically ebXML is being used in these environments.

The Classic ebXML model

This then forms the basis for what we can call ‘classic ebXML’, ebMS with CPAs orchestrating transaction exchange based processes between partners. While there is some limited involvement of Registry services in certain deployments the majority of implementations are done without using a formal Registry, instead websites perform the role of registry facilitation. The classic ebXML approach has proved its worth by also being the basis of a formal certification program for ebMS implementations. UCCNet provides this certification in cooperation with the eBusinessReady.org service. Now customers are able to purchase solutions that are guaranteed to be interoperable with each other. This is a critical advantage that ebXML has today.

Figure 1 – classic ebXML deployment components

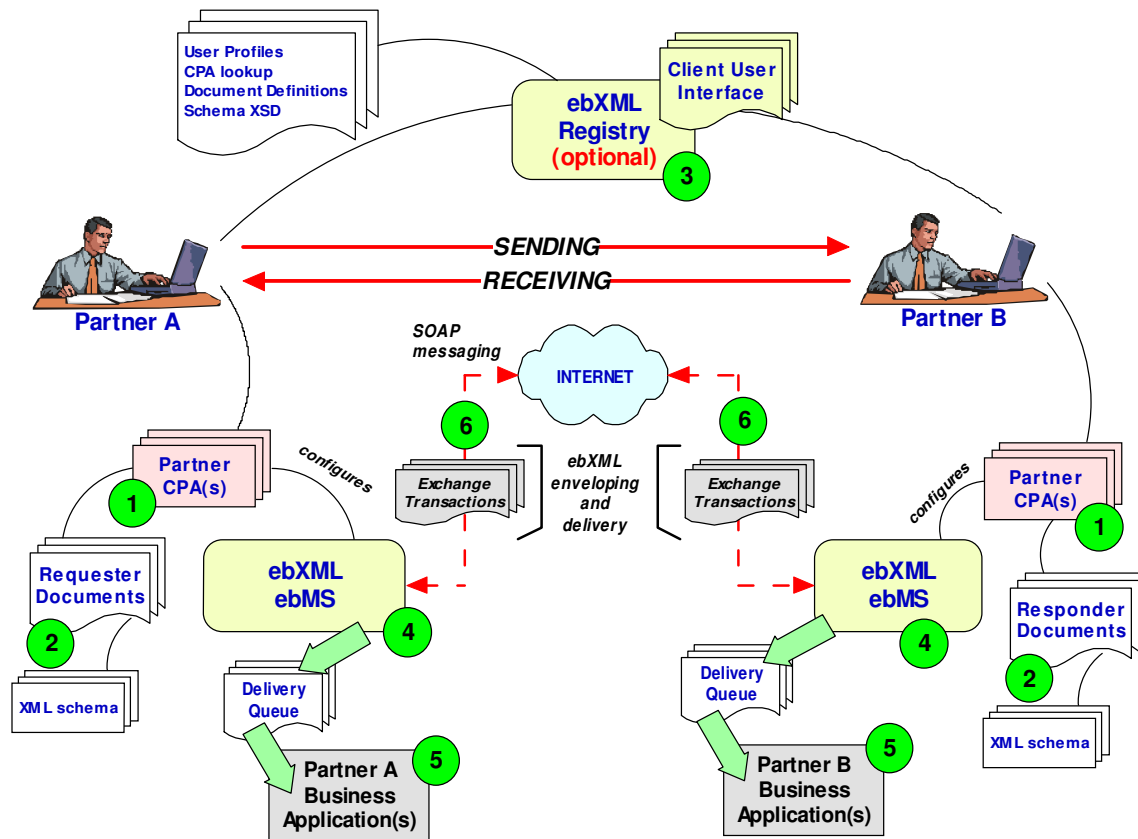

Using this classic ebXML model implementers create two-player business exchanges. An archetypal exchange is that of purchase orders, shipping notices and invoices between a buyer and a seller. In figure 2 below we see the activity model for such a Requester / Responder configuration that is supported using the classic ebXML components.

The individual main steps are ‘Create Order’ and ‘Order Fulfillment’, along with the business transactions that enable those. There is an initiating request from the requester

partner, and then the responder replies with a selection of transactions depending on the business state of the interaction, either rejecting or confirming the order accordingly.

The 'join' indicates that the process will only proceed when both an order confirmation and a ship delivery notice have been received. The 'fork' allows more than one action depending on a condition. In this case either a payment notice has to be created or not, based on the requirement of the particular supplier's application system (if it can reconcile electronic payments, or requires information to be able to reconcile them).

Figure 2 – classic ebXML Requester / Responder business activity model

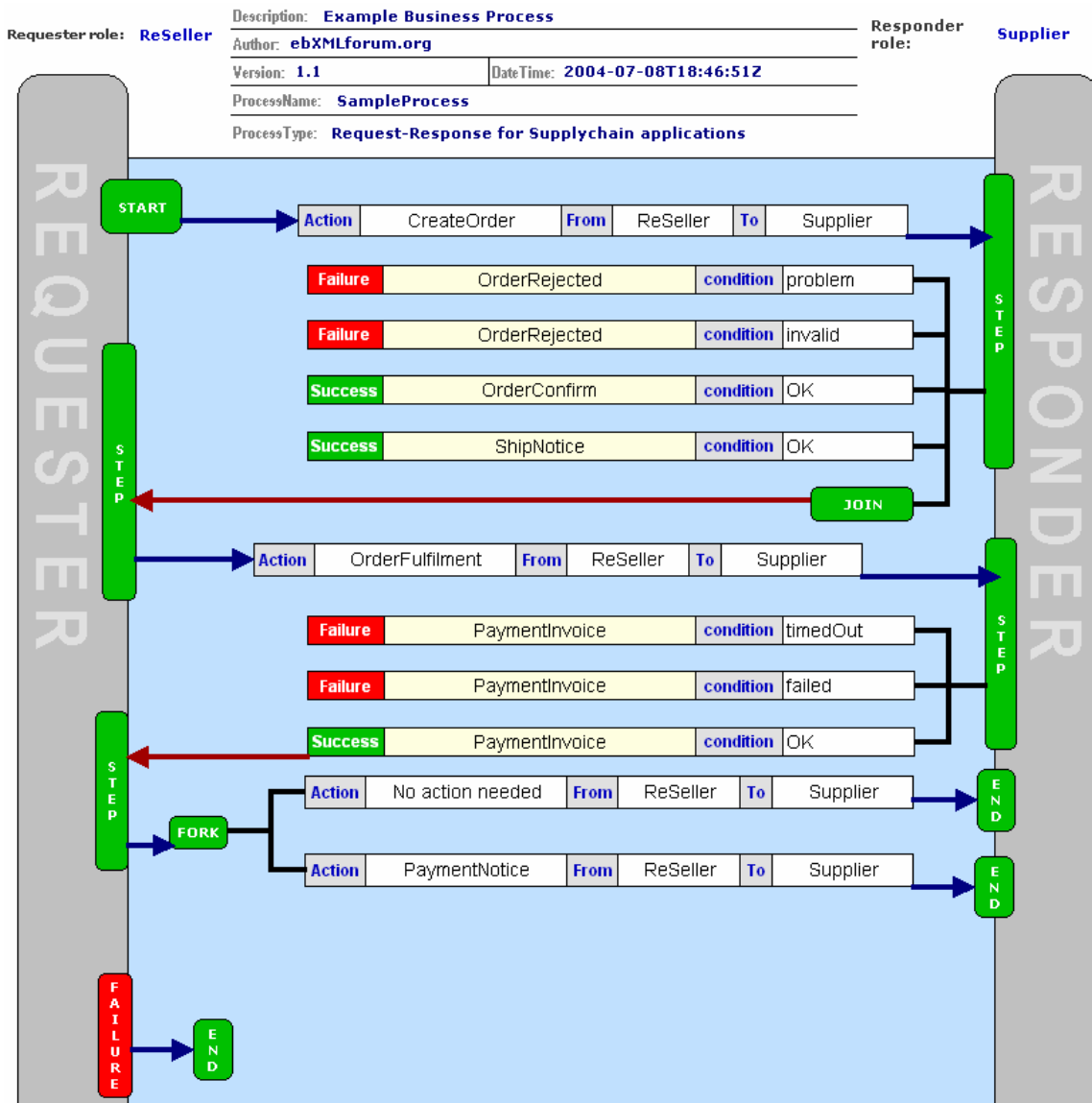

Figure 2 here shows various steps and business transaction exchanges involved in completing the sample purchase, delivery and payment for goods.

Advocates of web services have borrowed from this classic ebXML model with some important and critical differences. Web services are not based around formal business transaction exchanges but just fragments of information within an XML instance and instead of the formal CPA business agreements; they use WSDL (Web Service Description Language) scripts that are a programming device for describing the connections and software services, but not the business function. The failure and success guard conditions are not formally defined for a WSDL based exchange. Also web services are intended to perform in real-time as instant interaction points, whereas ebXML messaging can also exploit a batch operating mode with persistent and guaranteed authenticated message delivery. Instant interaction is also a tougher environment to manage, often exposing implementers to higher risks of exploitation through unscrupulous users of the Internet itself. Fortunately these technologies are not mutually exclusive and the savvy implementers understand how to use both together to provide a suite of capabilities to their users. We consider this environment next.

Delivering Enhanced ebXML

So far we have looked at ebXML being used in traditional environments where the interactions follow the same patterns validated by EDI systems for over twenty years. However the next level of integration reaches out to a wider world that is being created by advances in technology including mobile computing, wireless networking, and global communications combined with Internet-based marketplaces. This world creates complex multi-faceted multi-layered interactions between partners and services, including both traditional services and web services (such as credit validation, stock price lookup, and airline seat availability and so on). These multi-step processes cannot be modelled using just a simple request/response interaction paradigm alone.

Bringing the world of classic ebXML together with the web service instant interaction model is the challenge facing the industry today. Fortunately ebXML began the process of providing the necessary components in its initial foundation work. We will now look how this is coming into the forefront of enabling these next generation systems.

In order to formalize the interaction between partners ebXML uses the Business Process Specification Schema - BPSS component. This works in tandem with the ebMS and CPA by capturing the specific steps needed to complete a whole interaction between many participants. Classic ebXML finesses this in implementations today by using a common binary requester / responder model that works for most simple exchange patterns in business involving two parties, or that can be modelled as sets of such 'two-player' exchanges. Now however BPSS V2 is available and this is set to alter the whole landscape of business process engineering by providing the means to model and deploy sophisticated reliable and robust exchanges between multiple parties, not just limited to two.

This 'enhanced ebXML' provides the means to completely define a true Service Oriented Architecture (SOA) solution, including not just ebXML but also web service components in a holistic way. Figure 3 shows a deployment of this enhanced ebXML today.

Figure 3 – enhanced ebXML for SOA solutions

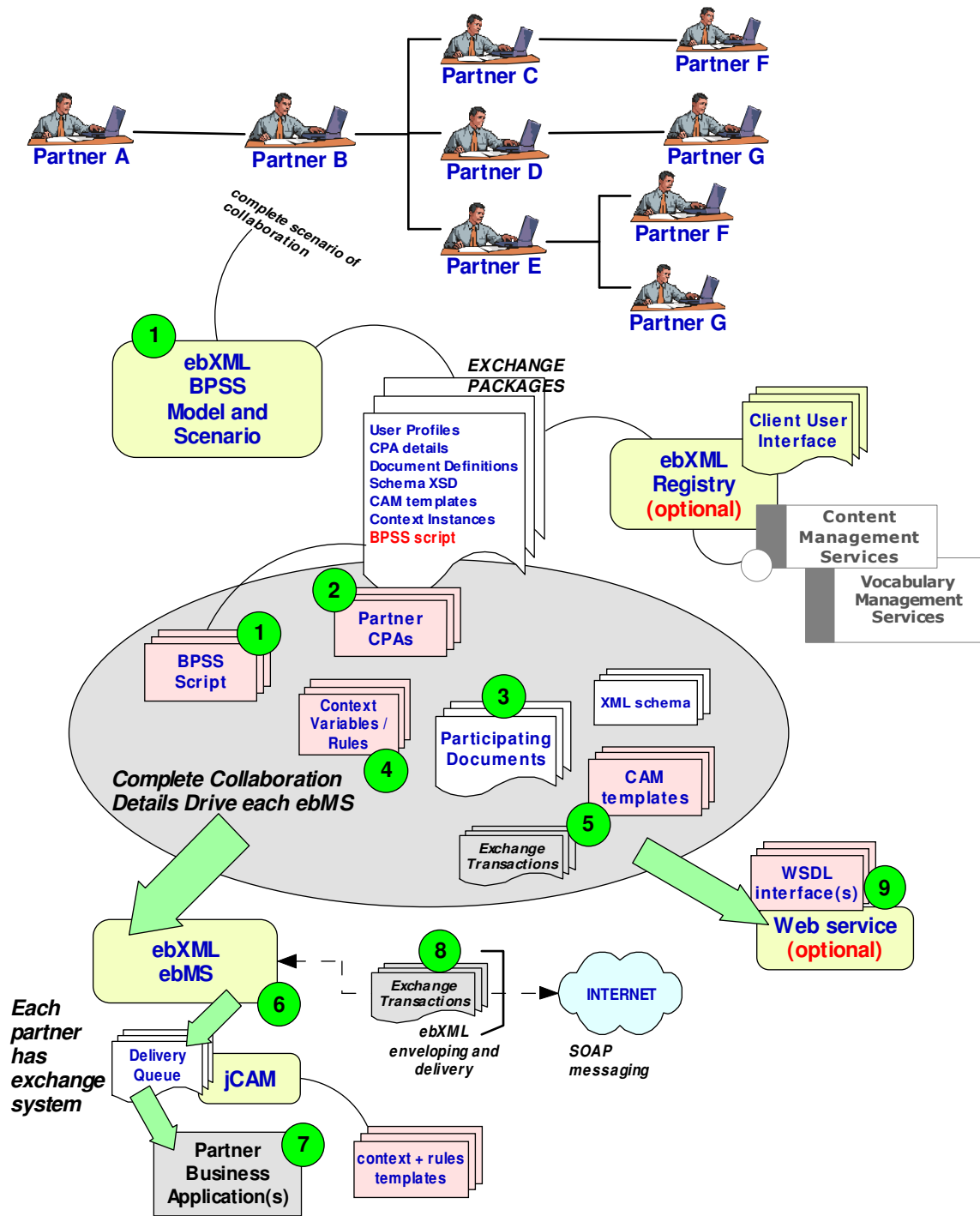

To support enhanced ebXML the new BPSS V2 provides key functionality that is once again groundbreaking for e-Business via the Internet. The first change allows roles and steps to be defined for multiple participants along with process forks and joins and thus extends the original ‘two-player’ ebXML exchanges to include extended interactions between many partners. But instead of this being more confusing spaghetti of complex

flows, the BPSS approach forces constrained deterministic business process steps to be defined between participants with single entry and exit points. The activity diagram in Figure 4 below shows how this works. This is crucial for defining real usable and enforceable business agreements. Now industry groups have the means to define exchanges for their members that can be re-usable and stable².

However building such exchange models in the past has been difficult because of the need to support local customization and variables. Again BPSS V2 provides the answer through managing context across the whole business process by participant (item #4 in figure 3 above). This allows local conditions to be resolved and special requirements to be integrated seamlessly. Local players in a marketplace can individually configure their own special context requirements and tie those to their role and exchanges.

The third piece that BPSS V2 adds is the ability to integrate into the application layer provided by existing business application systems. By providing context in a formal XML-based way – the BPSS can pass that context to the underlying integration systems. In addition logical business transaction handling can be mapping to physical integration services directly using the document definitions that BPSS provides. OASIS has also developed an open source solution to even further expedite this called the OASIS Content Assembly Mechanism (CAM) that uses simple XML-based scripts to document the business rules needed (item #5 in figure 3 above). Simply put these give participants the ability to pre-packaged information integration scripts in XML and then share those. This greatly enhances the consistent information flow between partners systems.

Put together this allows business users to now use the Registry services to fully document their end-to-end exchanges using XML structures as a coherent package. A typical such package can contain CPA, BPSS and CAM definitions along with traditional ubiquitous XML tools such as transaction schemas defined in either XSD or DTD syntax. By sharing such a package across an industry this allows partners to quickly configure their own ebXML systems and begin doing business, rather than having to endure a long and costly setup.

To accommodate web service based interactions, BPSS V2 also provides an ability to include WSDL-based steps into a BPSS model (item #9 in figure 3 above). These use a limited interaction model that provides the means to control and manage those steps using the ebXML approach. This does not include all web services, but only this discreet set of formally structured web service interactions. The key is to provide a deterministic and known business implementation where all end-conditions are known in advance.

By exploiting this enhanced ebXML implementers can provide the most complete e-Business services environment available today. BPSS sits at heart of the components and conducts the orchestra of components. Providing business context, transaction integration, process management, partner role details and deterministic transport messaging delivery flows.

² The OASIS UBL work on Universal Business Process (UBP) is already working on scenarios using BPSS

Using this model figure 4 shows a complex multiparty interaction and how the components and participants interact together.

Figure 4 – Multi-party business collaboration using ebXML

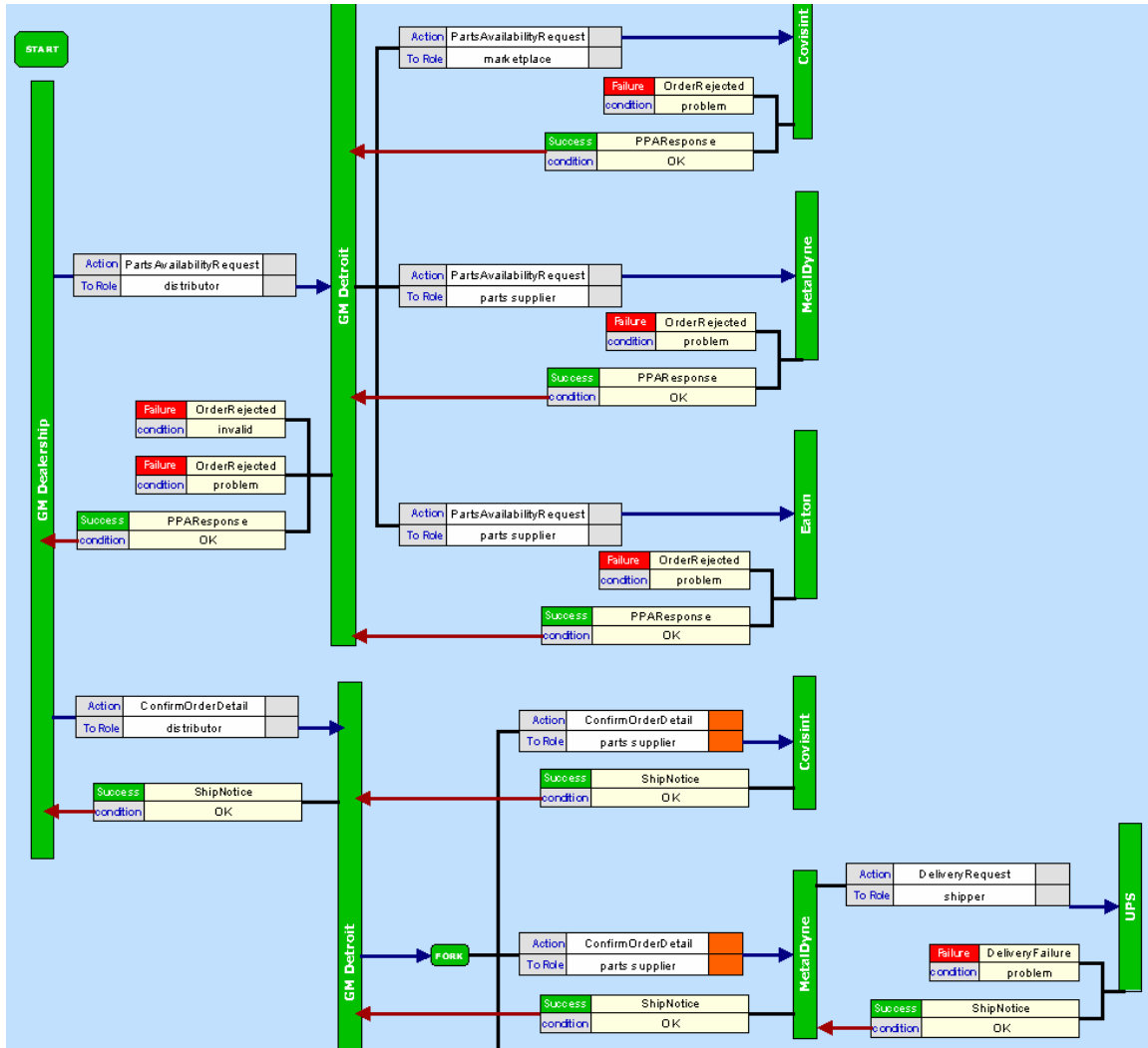

Figure 4 includes a multi-step interaction sample exchange between participants in an automotive industry supply-chain marketplace. Included in the diagram is the car dealership that is requesting a part supply, the manufacturer (General Motors) then querying their partners (Eaton, MetalDyne) and the automotive marketplace (Covisint). After consolidating the replies on parts available and price, they then notify the dealer who then confirms the order. The ship notices from the delivery carrier are then forwarded to the dealership. Being able to manage such as complex interaction, and allow each participant to configure their own profiles and business context parameters, along with message details (EDI or XML) is what the new enhanced ebXML systems are capable of directing. For more details on how to model all the aspects of the multi-party interaction, that enhance and compliment the activity diagram shown in figure 4, see the BPSS tutorial available online from the BPSS resource sites noted below.

Summary

The original vision of ebXML has proven to be robust and extensible to meet the demands of an increasingly more sophisticated information world. Enhanced ebXML provides a timely and important next step for ebXML deployments worldwide. As the supporting tools continue to mature we will see increasingly sophisticated usage of the ebXML solution stack of components meeting the expanding demand for reliable and proven e-Business solutions based on open public standards.

Beyond today's enhanced ebXML there are many more interesting aspects being worked on for ebXML that will be available in the future. Included in this is the integration of semantic web capabilities into ebXML Registry and ability to define core component libraries and vocabularies of business nouns. These tools will allow whole industries to deploy common foundation services based on coherent semantics and implement *Knowledge Based Collaboration (KBC)*. This is particularly of interest for emerging healthcare applications such as the caBIG³ work and HL7 based services.

Also important is the front-office facing development being done to provide a uniform e-Service infrastructure for citizen and customer facing applications. This work is based on the original Electronic Process (EPR) project funded in Europe (see <http://eprforum.org>) and is using the ebXML infrastructure to provide the linkage to the back-office systems. Related to this is the *Business-Centric Methodology (BCM)* work of OASIS that is seeking to provide catalogues of proven templates for business users to be able to adapt and exploit ebXML-based systems (see <http://businesscentricmethodology.com> and OASIS).

The business process work in ebXML is now advancing to collaborate with work by the OMG and BPMI groups⁴ to create an aligned set of methods with shared modelling constructs and methods for business analysts to represent actual business processes. Similarly the latest ebSOA work at OASIS is providing the foundations for ebXML and SOA solutions and allowing implementers to engineer robust process flows.

There are many more challenges ahead for the development of e-Business systems including the need to integrate RFID and Wireless mobile device based solutions but today we see that ebXML is evolving to meet these challenges. This development is not based on simply bolting-on technology however. Any new additions to ebXML are founded on the core concepts that are the strength of ebXML. The need is to provide secure, reliable, predictable and robust real business mechanisms and agreements that can meet the rigorous needs of internet enabled commerce today.

Authors and Contributors:

David RR Webber, Neil Wasserman, Ed Dodds, and Patrick Hogan

³ caBIG and HL7 project information <http://www.hhs.gov/healthit/federalprojectlist.html>

⁴ Object Management Group (OMG) and Business Process Management Institute (BPMI)

Resources and Selected Links

Latest news on global ebXML developments – <http://www.ebXMLforum.org>

Reference site to classic ebXML – <http://www.ebxml.org>

List of available ebXML tools – <http://www.ebxml.org/tools/>

List of example ebXML implementations – <http://www.ebxml.org/implementations/>

Book reference – Executive Introduction to ebXML – <http://www.ebxmlbook.com>

Developers' resource site – <http://www.ebxmldev.org>

Open source implementations of ebXML – <http://www.freebXML.org>

Linux Open Source Development Lab (OSDL) and ebXML – <http://www.osdl.org>

Specification work on ebXML at OASIS – <http://www.oasis-open.org>

Specification work relating to ebXML at UN/CEFACT - <http://www.untmg.org/>

Example automotive industry solutions provider - <http://www.oxlo.com/autoTPX.aspx>

Open Healthcare Framework (OHF) Project - <http://www.eclipse.org/ohf/>